

# CHERRY COMMERCIAL RIVETS

## CHERRY AEROSPACE RIVETS - SELF-PLUGGING CHERRY RIVETS

### 100° COUNTERSUNK (CR9162)



The self-plugging Cherry Blind Rivet is a 2-piece assembly - a hollow rivet and an inner member or stem, drawn into or through the hollow rivet. Cherry CR162 & CR163 series rivets are now replaced by CR9162 & CR9163 series rivets which are less expensive but does require the use of a rivet gun that comes with the req. nosepiece. Pulling Head (required) .....P/N 04-01515 .....\$772.00  
**G-29 Rivet Gun** - Comes equipped with a 728A9-3 nosepiece to install 3/32" rivets and has a 728A9-104 nosepiece stored in the handle for installing 1/8" rivets.....P/N 12-00701 .....\$161.75

### UNIVERSAL HEAD (CR 9163)



Part No.	Head Style	Nominal Dia.	Grip Range	Price		
				Each	100	1000
CR9162-4-2	Csk	1/8"	.063-.125	\$0.34	\$30.60	\$272.00
CR9162-4-4			.188-.250	\$0.49	\$44.10	\$392.00
CR9162-4-6			.313-.375	\$0.71	\$63.90	\$568.00
CR9162-4-8			.438-.500	\$0.57	\$51.30	\$456.00
CR9163-4-2	Univ.	1/8"	.063-.125	\$0.39	\$35.10	\$312.00
CR9163-4-4			.188-.250	\$0.50	\$45.00	\$400.00
CR9163-4-6			.313-.375	\$1.48	\$133.20	\$1,184.00
CR9163-5-2	Univ.	5/32"	.063-.125	\$0.67	\$60.30	\$536.00

## CHERRY N RIVETS

Break mandrel rivets Conform to MIL-R-24243 & IFI-114 Standards



### LOW COST

Substantial savings in installed costs can be realized when Cherry N Rivets are substituted for spotwelds, screws or bolts.

### FAST INSTALLATION

Quick and easy to use with hand or power riveters, Cherry N Rivets have endless fastening applications in manufacturing, maintenance.

### UNIQUE FEATURES

Unusual mandrel design of Cherry N Rivets holds rivet and mandrel firmly together prior to installation and insures positive mandrel retention in the installed rivet.

### NO MANDREL POP OUTS—

As the mandrel is drawn into the rivet, the end of the rivet sleeve closes in an elliptical configuration... locking the mandrel firmly in place!

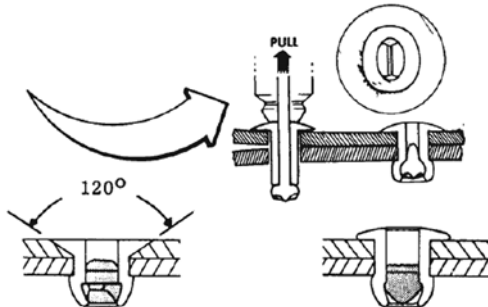

### FLUSH HEAD PROTRUDING HEAD CHERRY N RIVET IDENTIFICATION CODE

#### First letter is rivet material:

A = 5052 Aluminum    B = 5056 Aluminum    C = Stainless  
 M = Monel    S = Steel    U = Copper

#### Second letter is mandrel material:

A = 7178 Aluminum    S = Steel    C = Stainless

#### Third letter is head style:

P = Protruding    L = Large    C = Flush

#### First number is rivet diameter in 32nds of an inch:

For example,—4 is 4/32nds or 1/8" diameter

#### Second number is rivet maximum grip length in 16ths of an inch:

For example,—6 is 6/16ths or 3/8" grip length

### MINIMUM RIVET SHEAR AND TENSILE STRENGTH (IBS.) CHERRY N RIVETS

Rivet Dia. Mand.	BS Series Alum Rivet Steel Mand.		MS Series Monel Rivet Steel Mand.		CC Series Stainless Rivet Stainless	
	Grade 19		Grade 40		Grade 51	
	Shear	Tens	Shear	Tens	Shear	Tens
3/32	125	175	200	300	230	280
1/8	200	325	350	525	450	600
5/32	325	450	600	900	750	1000
3/16	430	650	750	1100	1000	1300
1/4	750	1050	1450	2150	1700	2250

## CHERRY Q RIVETS

Structural—Self-plugging rivets



### HIGH SHEAR STRENGTH

Cherry Q Rivet mandrel plugs the entire length of the rivet sleeve, providing full shear strength values for structural or load-bearing applications.

### SEALING CAPABILITY

Specially designed mandrel of the Q Rivet is engineered to effect a seal, upon installation which offers resistance to leakage.

### VIBRATION RESISTANT

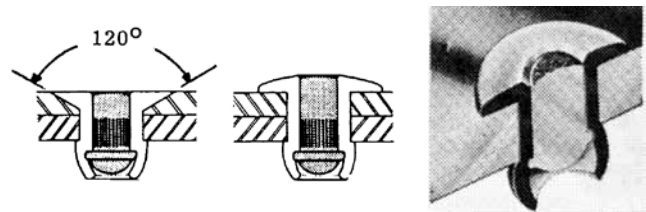

Rivet sleeve curls over end of mandrel to insure its positive retention.

### FLUSH HEAD PROTRUDING HEAD CHERRY Q RIVET IDENTIFICATION CODE

#### First letter is rivet material:

A = 5052 Aluminum    B = 5056 Aluminum    C = Stainless  
 M = Monel    S = Steel

#### Second letter is mandrel material:

A = 7178 Aluminum    S = Steel    C = Stainless

#### Third letter is head style:

P = Protruding    L = Large    C = Flush

#### Fourth letter is type of rivet:

Q = Cherry Q Rivet, structural, self-plugging

#### First number is rivet diameter in 32nds of an inch:

For example,—6 is 6/32nds or 3/16" diameter

#### Second number is rivet maximum grip length in 1/16 of an inch:

For example,—8 is 8/16ths or 1/2" grip length

### MINIMUM RIVET SHEAR AND TENSILE STRENGTH (IBS.) CHERRY Q RIVETS

Rivet Dia. Mand.	BS Series Alum Rivet Steel Mand.		MS Series Monel Rivet Steel Mand.		CC Series Stainless Rivet Stainless	
	Grade 19		Grade 40		Grade 51	
	Shear	Tens	Shear	Tens	Shear	Tens
5/32	525	450	950	900	1050	1000
3/16	750	650	1450	1100	1650	1300
1/4	1250	1050	2350	2150	2450	2250

NOTE: SUBJECT TO PRICE AND AVAILABILITY OF CHERRY BRAND RIVETS. EQUIVALENT RIVETS MAY BE FURNISHED.

WWW.AIRCRAFTSPRUCE.COM